

# SNAP Energy Monitoring Unit

## Features

- Monitors power usage for a 3-phase electrical device such as an HVAC system, engine, or pump
- Plots realtime and historical energy usage data in an easy-to-use HMI
- Sends email notification when energy usage is above preset levels
- Can be expanded and modified to suit your application

## Description

Opto 22's SNAP Energy Monitoring Unit (OptoEMU) is a complete package of Opto 22 hardware and software that lets you monitor energy usage for a 3-phase electrical device—such as an air conditioning and heating unit, pump, machine, or engine—so you can anticipate energy bills and respond quickly when energy use rises unexpectedly. The OptoEMU:

- Monitors power usage
- Provides real-time and historical energy usage data, including peak usage for each 24-hour period
- Calculates live kilowatt hours and stores accumulated KWH data usage for every hour
- Checks changes in energy, and sends email if KWH usage or the rate of increase is greater than a preset limit you determine
- Alerts you when power exceeds or fails to reach limits you set

The SNAP-IT-EMU1 hardware comes mounted and pre-wired in a sturdy polycarbonate industrial enclosure. The following hardware is included:

- A SNAP-PAC-R2 programmable automation controller (PAC), already programmed
- One SNAP-AIPM-3 three-phase power monitoring module
- Power supply

Software and complete documentation in Adobe® Acrobat® PDF format are included on a CD with the unit. Software includes a pre-built PAC Project Basic control program (already loaded on the PAC) and a human-machine interface (HMI) to monitor energy use. The HMI can be easily installed on a computer networked with the unit over a standard 10/100 Mbps Ethernet network.

The HMI provides a wealth of realtime and historic data in graphic plots, including:

- True power, volts, amps, and power factor
- Live kilowatt usage based on true power samples every second



**SNAP-IT-EMU1**

- Kilowatt hour usage per hour for a maximum of 24 hours
- Kilowatt hours for each 24-hour period
- Peak wattage and the time and date of occurrence (peak value resets at midnight)

### Use As Is or Modify for Your Needs

The OptoEMU comes ready to monitor one three-phase electrical device, but you can also expand or change it to suit your needs. Since the mounting rack can hold three more SNAP I/O modules (for a total of four), you can:

- Add additional SNAP-AIPM-3 modules to include other 3-phase electrical devices in your energy usage monitoring
- Add other SNAP I/O modules of any type (analog, digital, and serial) to control or monitor a wide range of other devices
- Change or add programming logic to the PAC Control strategy to incorporate additional devices
- Change or add to the PAC Display HMI

**NOTE:** The SNAP-IT-EMU1 is designed to monitor devices using 85–250 volts and 0–10 amps, but it can also monitor AC line currents greater than 10 amps using a standard current transformer (CT) of suitable ratio. For line voltage higher than 250 VAC, use a step-down potential transformer. If hazardous voltage or current is to be monitored, an interposing potential transformer and a CT must be used for safety.

### Part Numbers

Part	Description
SNAP-IT-EMU1	Monitoring system for electrical energy usage

# SNAP Energy Monitoring Unit

## Specifications

<b>Overall Unit</b>	
Power Requirements	120 VAC
Communication	10/100 Mbps Ethernet network interface (RJ-45 connector)
Backup battery	Rechargeable (recharges whenever the unit has power), 3-year power-off data retention
Operating Temperature	0 to 60 °C
Storage Temperature	-40 to 85 °C
Humidity	0–95% humidity, non-condensing
Enclosure	NEMA Type 4X polycarbonate
<b>SNAP-AIPM-3 Voltage inputs (each input)</b>	
Recommended Input Range	85 to 250 VAC RMS
Input Over Range	To 275 volts
Maximum Input	300 V
Input Resistance – Single Ended	1 Megohm (NOTE: Because both channels share the same reference terminal, <b>polarity must be observed</b> when connecting the current channel.)
<b>SNAP-AIPM-3 Current Inputs (each input)</b>	
Input Range	0 to 10 AC amps RMS
Input Over Range	To 11 amps (Reading is not reliable over 11 A.)
Maximum Input	15 A continuous
AC Common Mode Rejection	> – 120 dB at 60 Hz
Maximum Operating Common Mode Voltage	250 VAC
Input Resistance – Single Ended	0.005 Ohm (NOTE: Because both channels share the same reference terminal, <b>polarity must be observed</b> when connecting the voltage channel.)

## Software Installation Requirements

- Computer with at least the minimum processor required for your version of Microsoft® Windows® (single or dual core, 1 GHz Pentium®-class or better recommended) and Ethernet capability.
- Windows Vista® Business (32-bit), Windows XP Professional (with SP2 or higher) or Windows 2000® (with SP4) workstation operating system. (Microsoft Windows server, 64-bit versions of Windows workstation, and embedded operating systems are not supported.)
- At least 1 GB RAM for Windows Vista, or at least 512 MB for Windows XP or Windows 2000.
- VGA or higher resolution monitor (Super VGA recommended), minimum size 800x600 with small fonts.
- Mouse or other pointing device. Printer optional.
- Available hard disk space required: 124 MB

# SNAP Energy Monitoring Unit

## Dimensional Drawing—SNAP-IT-EMU1

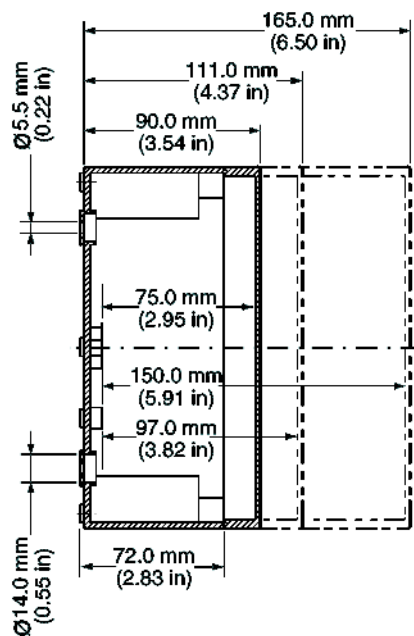
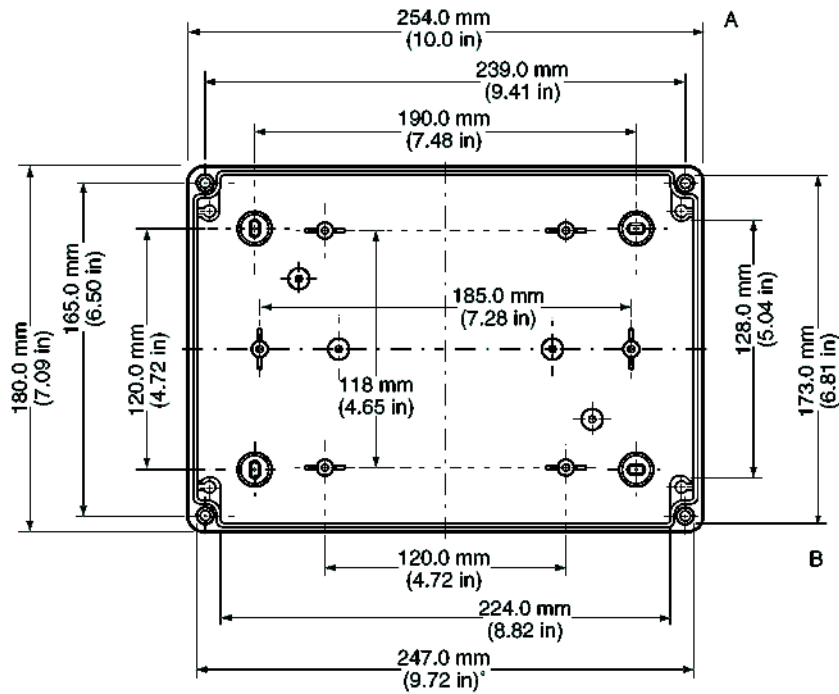

# SNAP Energy Monitoring Unit

## Wiring Diagrams—SNAP-AIPM-3

### Three-Phase Wiring to SNAP-AIPM-3 Module

NOTE: Use either this diagram or the one on page 5.

**CAUTION:** Be very careful when connecting input channels. **Do not connect line voltage to the current input channel;** such a connection will cause **severe damage** to the module. This damage is **not covered by warranty**. Use a current transformer instead.

**CAUTION:** Use caution when selecting wire gauges for your application. Use conservative wire gauges with proper voltage ratings.

**CAUTION:** Terminals 3, 4, 5, and 6 share a common connection inside the module. **Make sure you observe polarity** when connecting the second channel. To avoid a potentially hazardous short circuit, double-check wiring before turning on the current to be monitored.

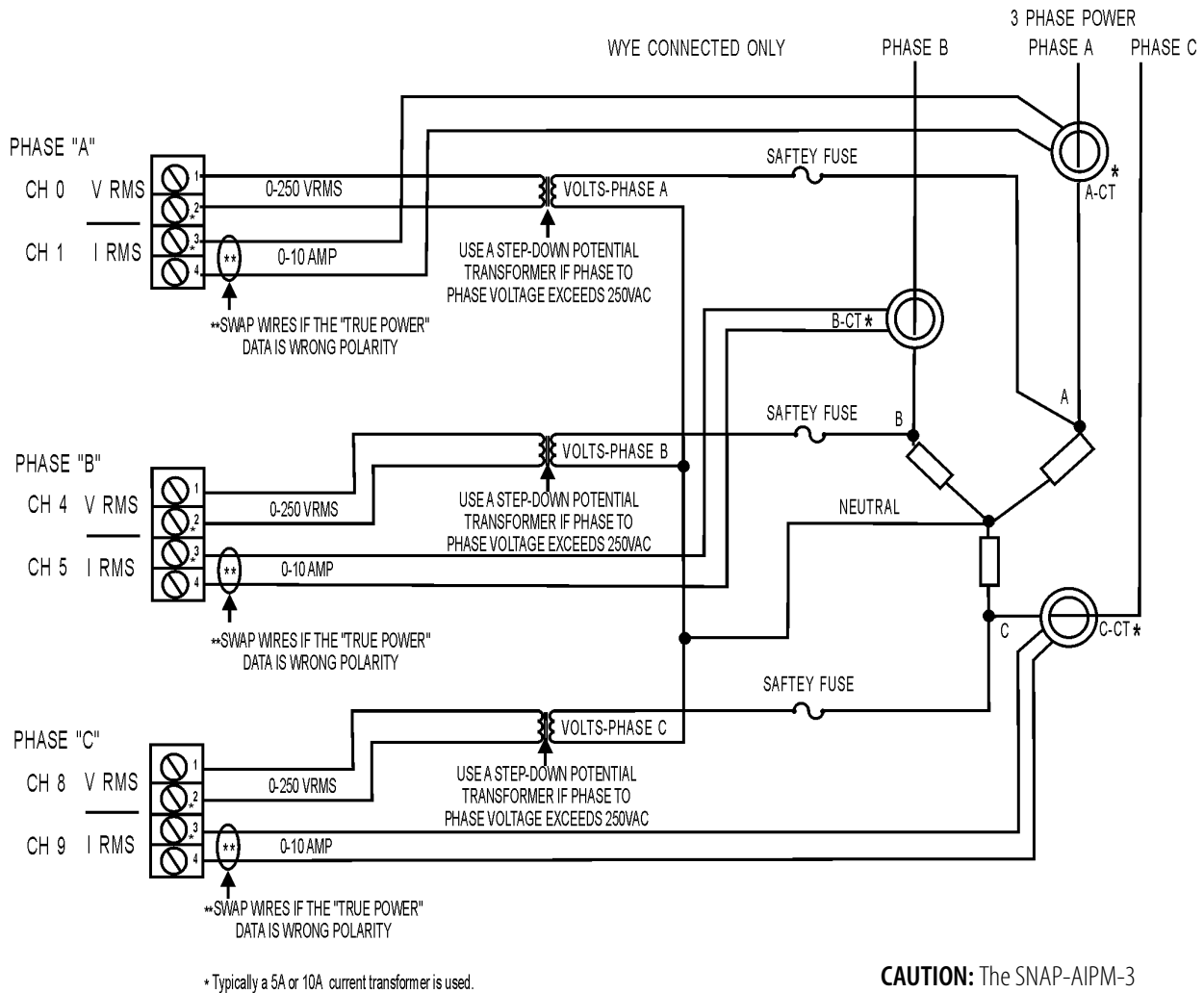

**CAUTION:** The SNAP-AIPM-3 module does not contain a fuse. Protect the system by adding fuses.

#### Suggested vendors

Protection fuses:  
<http://www.littelfuse.com>  
 Voltage and current transformers:  
<http://www.crmagnetics.com>

Using this wiring, after you scale the module, the following measurements are available. All measurements are synchronously updated every second:

<ul style="list-style-type: none"> <li>• Individual phase to neutral voltage</li> <li>• Individual phase and load current</li> <li>• Individual phase power</li> <li>• Individual phase volt-amps</li> </ul>	<ul style="list-style-type: none"> <li>• 3-phase sum of 1 sec.—signed energy (watt seconds)</li> <li>• 3-phase sum of 1 sec.—unsigned energy (watt sec)</li> </ul>
--	--

# SNAP Energy Monitoring Unit

## Wiring Diagrams—SNAP-AIPM-3

### Three-Phase Wiring to SNAP-AIPM-3 Module

NOTE: This wiring method is less expensive than the one on [page 4](#) but does not provide as much information.

**CAUTION:** Be very careful when connecting input channels. **Do not connect line voltage to the current input channel;** such a connection will result in **severe damage** to the module. This damage is **not covered by warranty**. Use a current transformer instead.

**CAUTION:** Use caution when selecting wire gauges for your application. Use conservative wire gauges with proper voltage ratings.

**CAUTION:** Terminals 3, 4, 5, and 6 share a common connection inside the module. **Make sure you observe polarity** when connecting the second channel. To avoid a potentially hazardous short circuit, double-check wiring before turning on the current to be monitored.

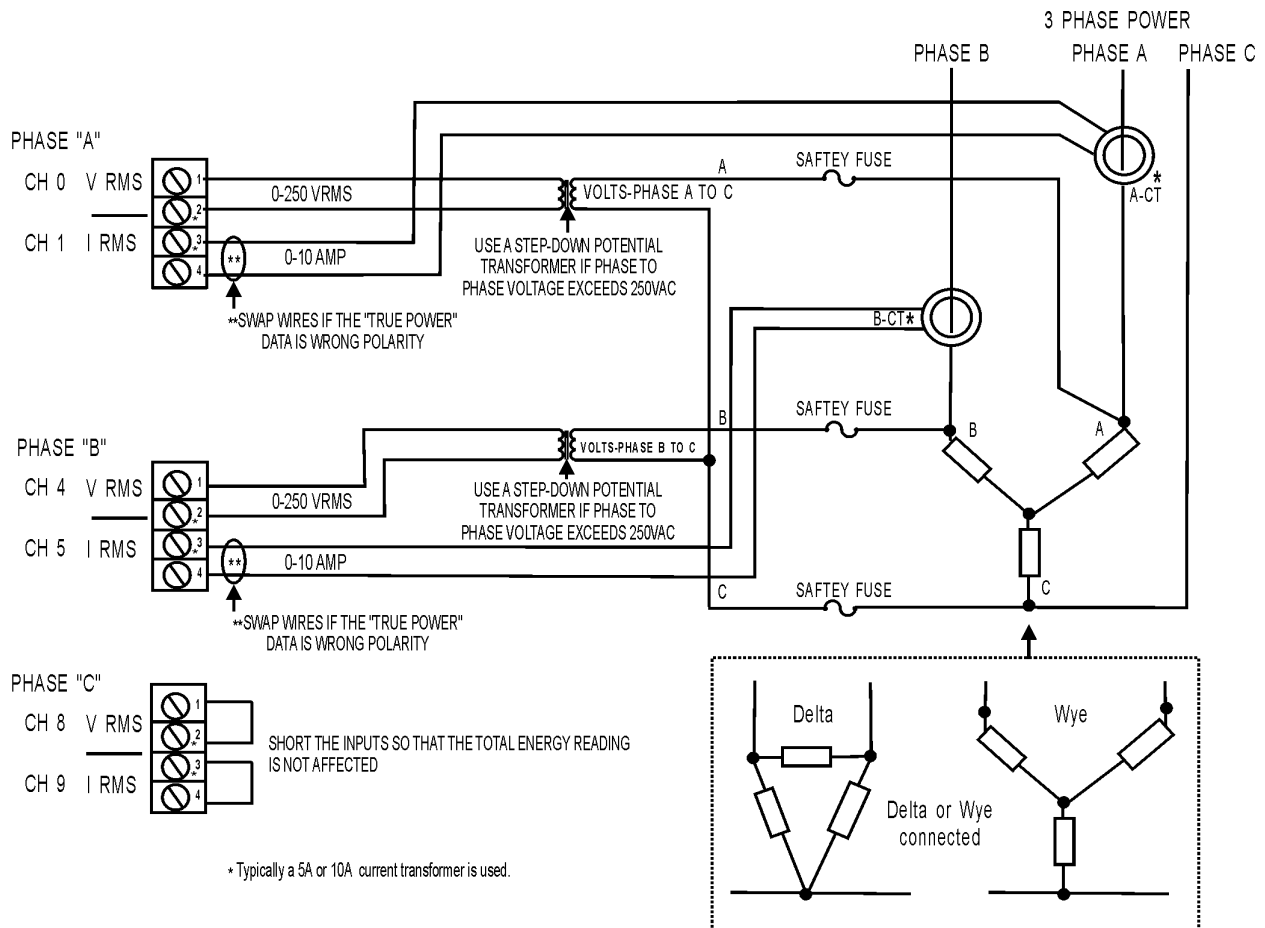

Using this wiring, after you scale the module, the following measurements are available. All measurements are synchronously updated every second:

- |                             |  |
|-----------------------------|--|
| • Volts, phase A to phase C | • 3-phase sum of 1 sec.—signed energy (watt seconds) |
| • Volts, phase B to phase C | • 3-phase sum of 1 sec.—unsigned energy (watt secs)  |

**CAUTION:** The SNAP-AIPM-3 module does not contain a fuse. Protect the system by adding fuses.

#### Suggested vendors

Protection fuses:  
<http://www.littelfuse.com>  
Voltage and current transformers:  
<http://www.crmagnetics.com>